

FLEXIBILITY FOR INNOVATORS ONLY

MONTECH[®]

COMPACT
FLEXIBLE
PRECISE



COMPACT- UNIVERSAL SLIDES



COMPACT UNIVERSAL SLIDES KUS CONTENTS

PRODUCT DESCRIPTION **170-172**



COMPACT UNIVERSAL SLIDES **173**



**CALCULATION PRINCIPLES/
ASSEMBLY INSTRUCTIONS**
174-176

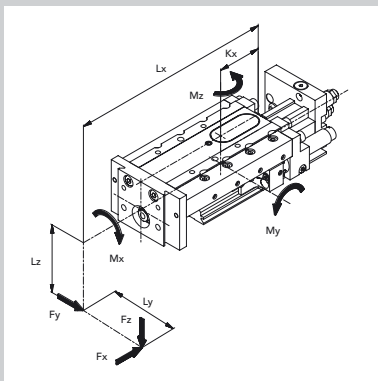

**DEFORMATIONS/
FORCE DIAGRAMS** **177-179**

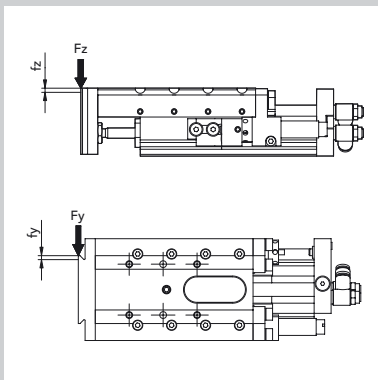

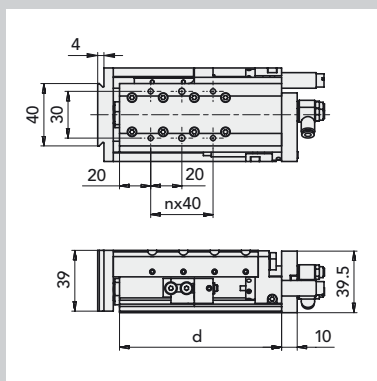
**TECNICAL DATA/
DIMENSIONS**

180-185

**SPECIAL ACCESSORIES
KUS**

186

**ESCAPEMENT**

188

COMPACT UNIVERSAL SLIDES KUS DESCRIPTION

The **Compact Universal Slide KUS** has a robust design with very high rigidity and a long life.

At strokes of min. 20 mm to max. 240 mm, the maximum installation mass is 10 kg.

In three sizes with piston diameters from 16 to 25 mm, four stroke lengths are available.



Ball bearings



Stop adjustment



Cage for ball synchronization.

Adjustable end stops
(maximum absorption).Adjustable end stops
(minimum absorption).Adjustment of the absorption
screw.

The high rigidity is achieved by **ball bearings with a gothic profile**. **Ball synchronization** is ensured by means of a **cage with integrated lubricant reservoir**.

Hydraulic shock absorbers act as end stops.

The **absorption characteristics** can be **adapted** to the application, guaranteeing an optimal cycle time.

Both **end stops** are **continuously adjustable** by 20 or 40 mm, depending on the size.



Proximity switch for retracted position.



Proximity switch for extended position.



Air connections



Dovetail mount and fixing bores.



Compensating spring

The two end positions can be detected with two **inductive proximity switches**. In the case of a stroke adjustment, the proximity switches don't need to be adjusted.

Pluggable air connections with adjustable exhaust throttles at the back of the slide ensure optimum accessibility.

For maximum installation flexibility, the slide has both Quick-Set[®] dovetail mounts, threads and positioning holes on three sides.

For vertical use, a compensating spring (special accessories, page 186) is available, which also ensures uniform movement and an optimum cycle time in vertical operation at maximum load.

COMPACT UNIVERSAL SLIDES KUS



Three sizes with piston diameter of 16, 20 and 25 mm.

SCOPE OF DELIVERY

Compact Universal Slide with two hydraulic shock absorbers, two integrated holders for inductive proximity switches, two exhaust throttles with plug-type connection and a comprehensive operating instruction.

SUITABLE ACCESSORIES

Special accessories
Accessories

Quick-Set®

page 186
from page 302
(see also assembly instructions from page 176)
from page 338

COMPACT UNIVERSAL SLIDES KUS CALCULATION PRINCIPLES

The load values given in the technical data are maximum values for a single load.
For the combined loads occurring in practice, the following calculations are applicable:

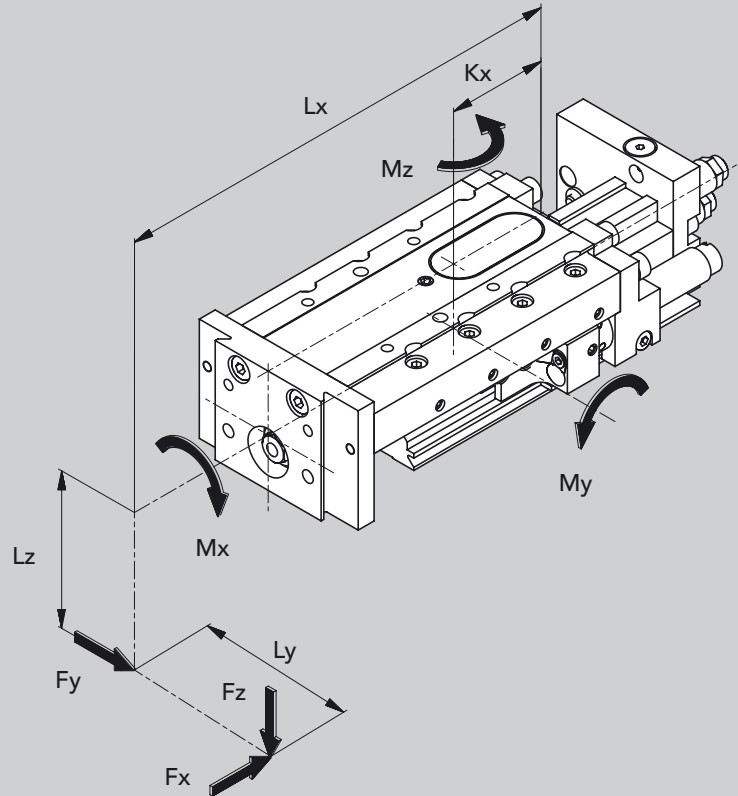

LOAD CALCULATIONS

a) Dynamic loading for horizontal use

$$M_x = 0.001 \cdot m \cdot g \cdot L_y$$

$$M_y = 0.001 \cdot m \cdot (g \cdot (L_x - K_x) + 25 \cdot L_z)$$

$$M_z = 0.001 \cdot m \cdot 25 \cdot L_y$$

Combined dynamic loading for horizontal use:

$$B = \frac{M_y}{M_{y \max}} + \frac{M_x + M_z}{(M_x + M_z)_{\max}} \leq 1$$

b) Dynamic loading for vertical use

$$M_y = 0.001 \cdot m \cdot (g + 25) \cdot L_z$$

$$M_z = 0.001 \cdot m \cdot (g + 25) \cdot L_y$$

Combined dynamic loading for vertical use:

$$B = \frac{M_y}{M_{y \max}} + \frac{M_z}{M_{z \max}} \leq 1$$

c) Static loading

$$M_{0x} = 0.001 \cdot (F_y \cdot L_z + F_z \cdot L_y)$$

$$M_{0y} = 0.001 \cdot (F_x \cdot L_z + F_z \cdot (L_x - K_x))$$

$$M_{0z} = 0.001 \cdot (F_x \cdot L_y + F_y \cdot (L_x - K_x))$$

Combined static loading:

$$B_0 = \frac{M_{0x}}{M_{0x \max}} + \frac{M_{0y}}{M_{0y \max}} + \frac{M_{0z}}{M_{0z \max}} \leq 1$$

B, B ₀ :	Load factor: Must not exceed the value 1!
M _i , M _{0i} :	Existing moments [Nm]
M _{i max} , M _{0i max} :	Max. permissible moments [Nm] (see table)
m:	Additional mass [kg]
L _x , L _y , L _z :	Center of gravity distance of the moving mass or distance of acting force [mm]
F _x , F _y , F _z :	Forces acting [N], max. value see «technical data» from page 180
K _x :	Constant according to table [mm]
g:	Acceleration due to gravity (9.81 m/s ²)

	K _x [mm]	Horizontal use		Vertical use		Static		
		M _{y max} [Nm]	(M _x + M _z) _{max} [Nm]	M _{y max} [Nm]	M _{z max} [Nm]	M _{0x max} [Nm]	M _{0y max} [Nm]	M _{0z max} [Nm]
KUS-16-20-SD	33	9	12	9	9	15	9	9
KUS-16-40-SD	36	10	13	10	10	18	12	12
KUS-16-60-SD	39	11	14	11	11	21	15	15
KUS-16-80-SD	42	12	15	12	12	24	18	18
KUS-20-40-SD	41	14	18	14	14	22	18	18
KUS-20-80-SD	47	17	20	15	15	27	26	26
KUS-20-120-SD	53	20	22	16	16	32	34	34
KUS-20-160-SD	59	23	24	17	17	37	42	42
KUS-25-60-SD	61	29	36	26	26	50	44	44
KUS-25-120-SD	73	36	42	28	28	62	66	66
KUS-25-180-SD	85	43	48	30	30	74	88	88
KUS-25-240-SD	96	50	54	32	32	86	110	110



When a projecting load (direction L_z) is installed on the end plate, it is essential to provide additional fixing on the slide to prevent oscillations (see assembly instructions page 176).

ASSEMBLY INSTRUCTIONS

When installing a projecting load (L_z direction) on the end plate, it is essential to provide additional fixing on the slide to prevent vibrations. Fixings of this type can be realized simply and quickly by using Quick-Set® elements.

e.g. inserter with revolver head:

A KW-40 bracket with two SLL-55-40 clamping elements is used as an additional fixing element for the vertical KUS.

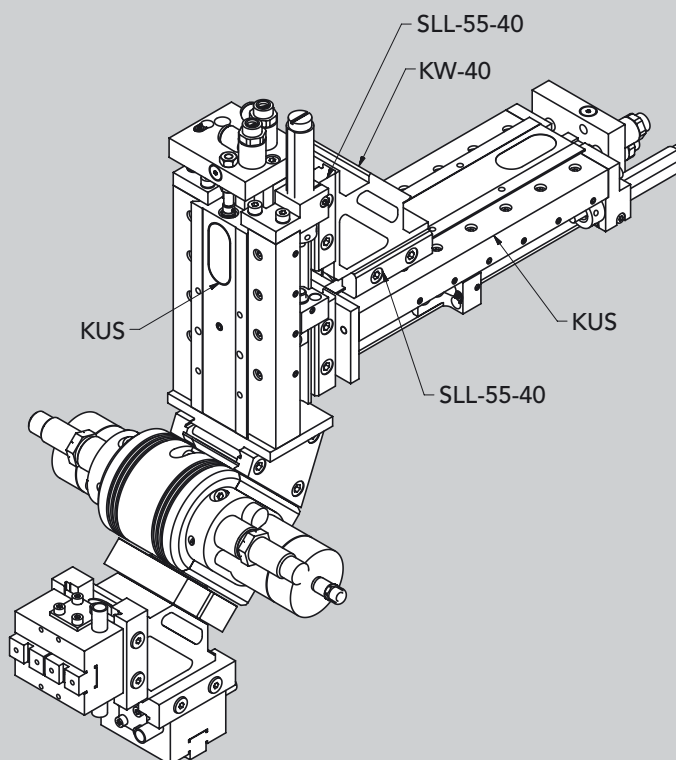

Inductive proximity switches:

The inductive proximity switch to be installed must fulfill the following conditions:

- Sensing distance: 2 mm
- flush-mountable
- housing diameter: 6.5 mm
- minimum housing length (\varnothing 6.5): 15 mm

e. g. MONTECH Ref. No. 504513, 504755, 501264 or 504609 (see accessories).

Connecting cable to pluggable proximity switches:

With the use of pluggable proximity switches, it is essential to use connecting cables with an angled socket due to the limited space available at the front position detection spot.

e. g. MONTECH Ref. No. 506488, 504929 oder 507529 (see accessories).

DEFORMATIONS

DEFINITION OF LOADS

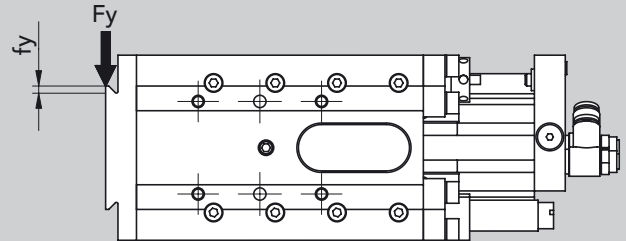
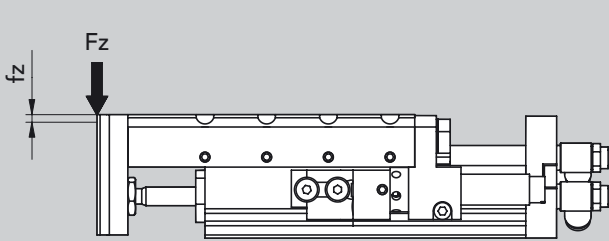

DEFORMATION DIAGRAMS

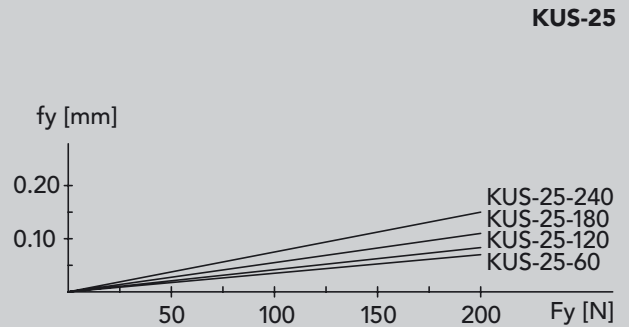
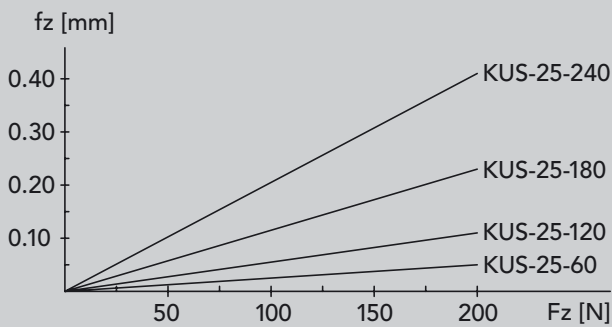
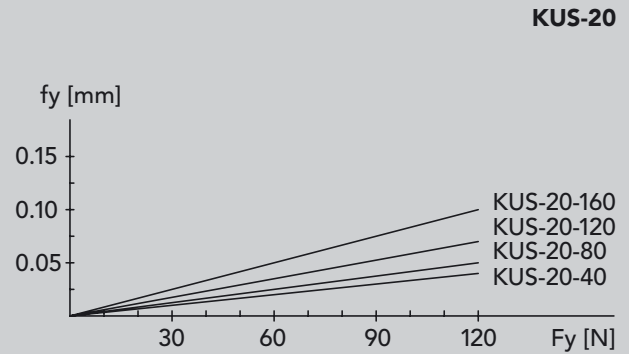
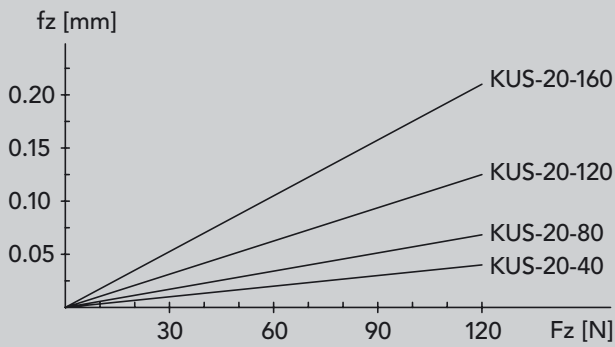
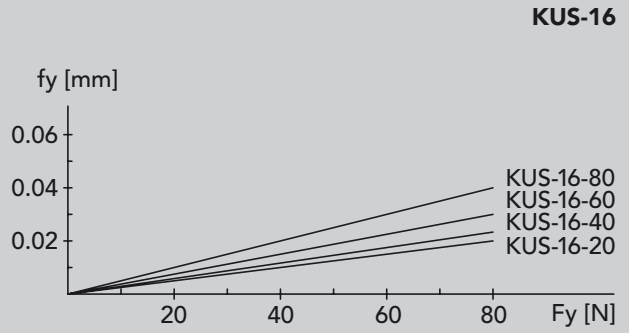
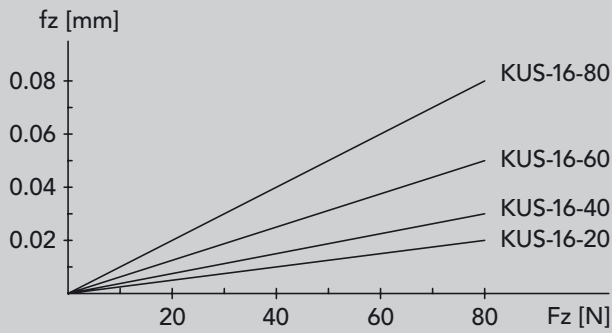

FORCE DIAGRAMS for KUS with installation kit for compensating spring

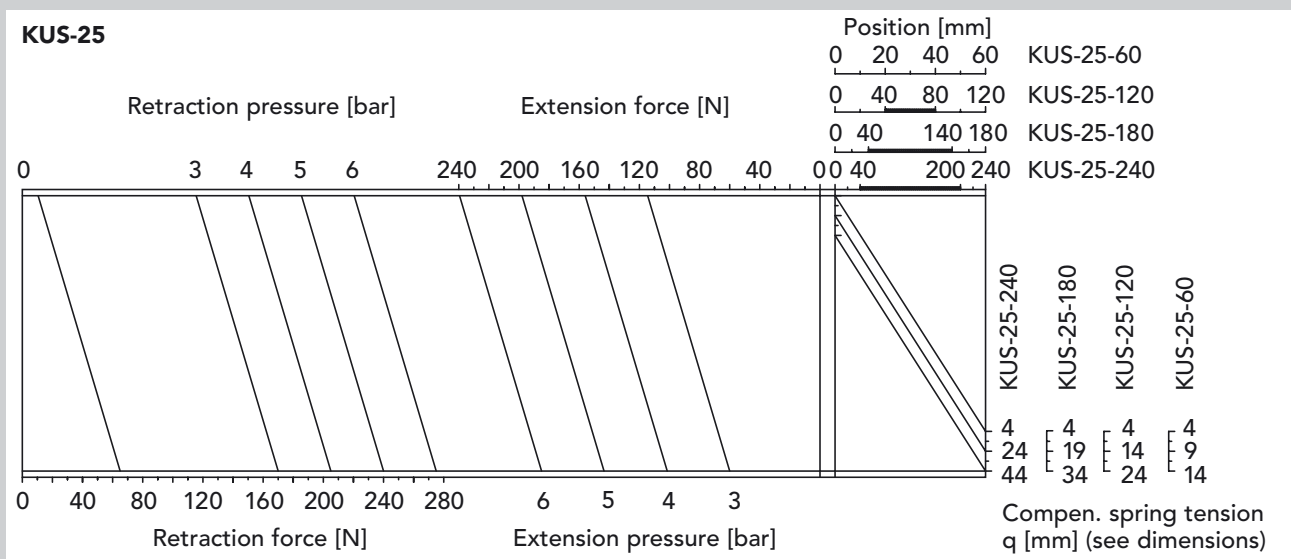
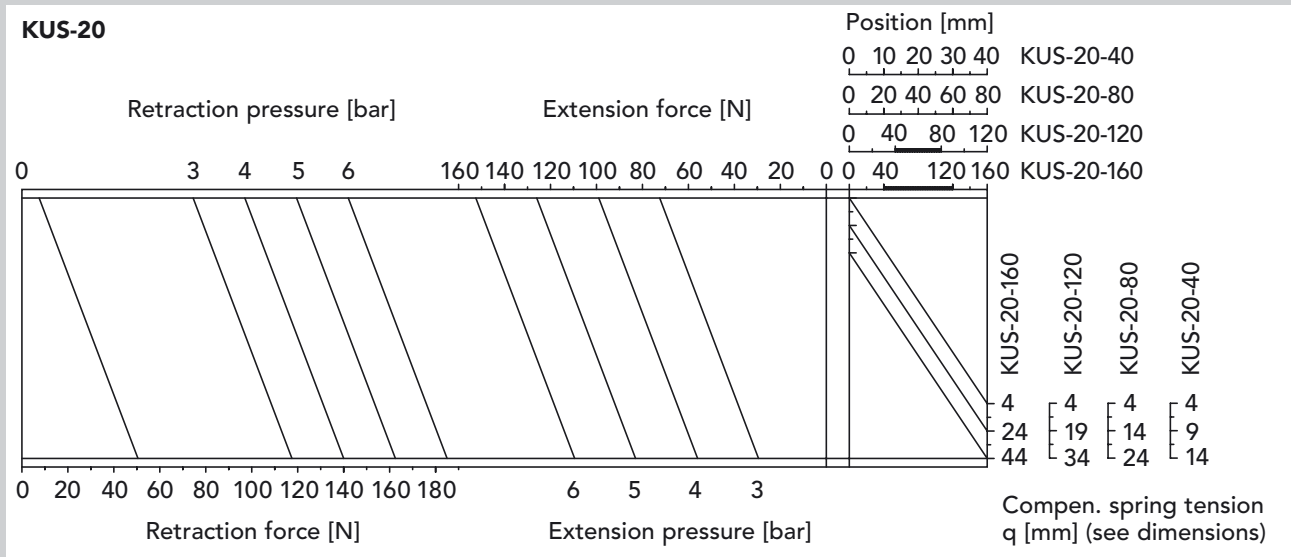
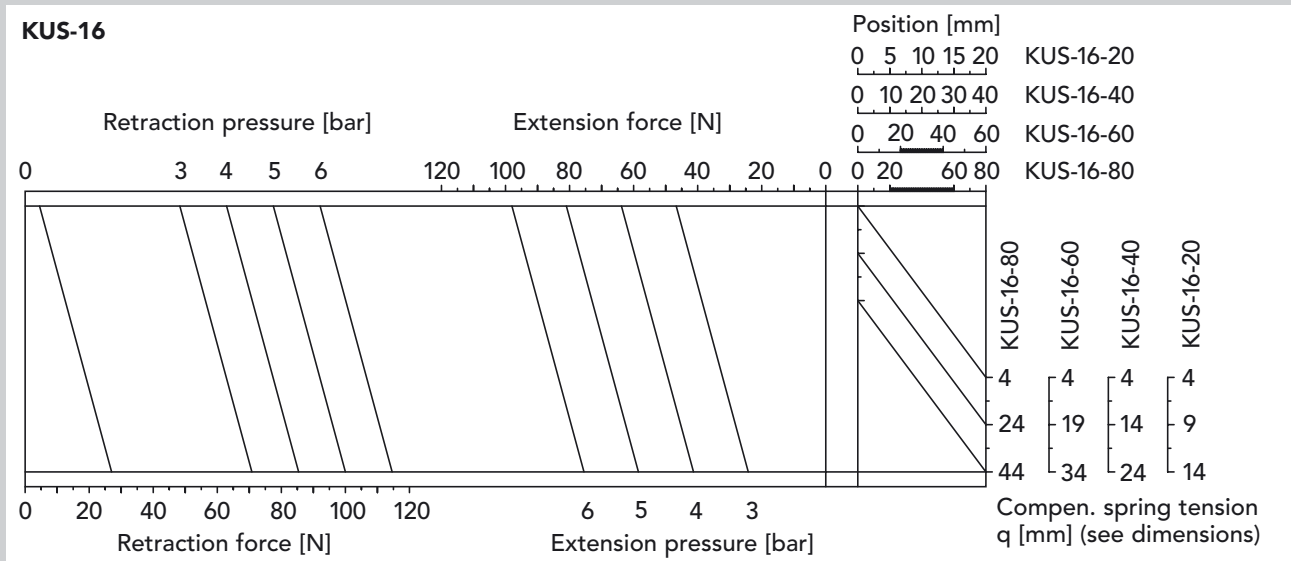

EXAMPLE TO FORCE DIAGRAM

Given: KUS-25-120 with installation kit for compensating spring
 Stroke: 70 mm (vertical, moving downwards)
 Pressure: 5 bar
 Additional mass: 6 kg

Searched: Retraction force in retracted state with compensating spring tension $q = 19$ mm
 Extension force in retracted state with compensating spring tension $q = 19$ mm
 Retraction force in extended state with compensating spring tension $q = 19$ mm
 Extension force in extended state with compensating spring tension $q = 19$ mm
 Retraction force in retracted state, without pressure, with compensating spring tension $q = 19$ mm
 Retraction force in extended state, without pressure, with compensating spring tension $q = 19$ mm

- Determine positions for KUS-25-120 (point a and point b): for the 70 mm stroke, the extended position is reduced by 40 mm (= max. stop adjustment range per side), position 80 mm results, and additionally the retracted position is reduced by 10 mm ($120 - 40 - 70 = 10$ mm). From points a and b, draw the lines 1 and 2 vertically downwards.
- Mark compensating spring tension $q = 19$ mm for KUS-25-120 (point c) and draw horizontal line 3 to edge of diagram (results in point d).
- From point d, draw line 4 parallel to the predetermined lines. The point of intersection with line 1 results in point e and the point of intersection with line 2 results in point f.
- From point e, draw horizontal line 5 to the left. The point of intersection with extension pressure 5 bar results in point g, the point of intersection with retraction pressure 5 bar results in point h and the point of intersection with retraction pressure 0 bar results in point i.
- From point g, draw vertical line 6 upwards, results in an **extension force in the retracted state** of 188 N. Adding the installation mass of 60 N to this results in **248 N**.
- From point h, draw vertical line 7 downwards, resulting in a **retraction force in the retracted state** of 194 N. Subtracting the installation mass of 60 N from this results in **134 N**.
- From point i, draw vertical line 8 downwards, results in a retraction force at **atmospheric pressure in the retracted state** of **20 N**, i.e. the installation mass of 60 N is **not** held in the upper end position at loss of pressure.
- From point f, draw horizontal line 9 to the left. The point of intersection with extension pressure 5 bar results in point k, the point of intersection with retraction pressure 5 bar results in point l and the point of intersection with retraction pressure 0 bar results in point m.
- From point k, draw vertical line 10 upwards, results in an **extension force in the extended state** of 161 N. Adding the installation mass of 60 N to this results in **221 N**.
- From point l, draw vertical line 11 downwards, results in a **retraction force in the extended state** of 222 N. Subtracting the installation mass of 60 N from this results in **162 N**.
- From point m, draw line 12 downwards, results in a **retraction force at atmospheric pressure in the extended state** of **47 N**, i.e. the installation mass of 60 N is not retracted from the lower end position at **loss of pressure**.

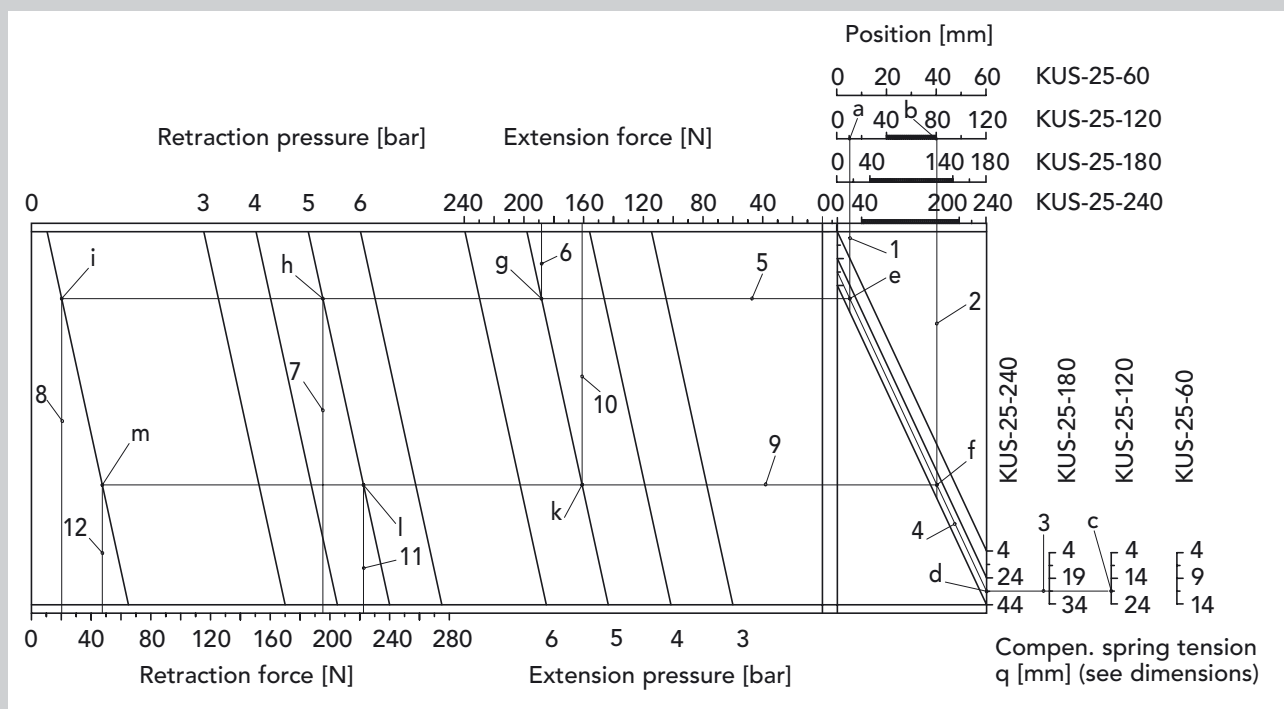

COMPACT UNIVERSAL SLIDES KUS-16-...-SD¹⁾

			KUS-16-20-SD	KUS-16-40-SD	KUS-16-60-SD	KUS-16-80-SD
Stroke (min./max.)	[mm]		5/20	5/40	20/60	40/80
Adjustment range for stops (per side)	[mm]		20	20	20	20
Piston diameter	[mm]		16	16	16	16
Piston-rod diameter	[mm]		6	6	6	6
perm. additional mass horiz.	$m_{h \max}$	[kg]	4	4	4	4
perm. additional mass vert.	$m_{v \max}$	2) [kg]	3	3	3	3
max. static moment	$M_{0x \max}$	3) [Nm]	15	18	21	24
max. static moment	$M_{0y \max}$	3) [Nm]	9	12	15	18
max. static moment	$M_{0z \max}$	3) [Nm]	9	12	15	18
max. static force (at 5 bar)	$F_{x \max}$	3) [N]	60	60	60	60
max. static force	$F_{y \max}$	3) [N]	120	130	140	150
max. static force	$F_{z \max}$	3) [N]	120	130	140	150
Weight	[kg]		0.75	0.85	0.95	1.05
Operating pressure	[bar]		3–6			
Operating medium			oiled or unoled air, filtered to 5 μm , dew point < 6°C			
End stop absorption			hydraulic shock-absorbers			
Repeatability	4) [mm]		< 0.01			
Check of end position	5)		inductive proximity switches			
Pneumatic connection			hose- \varnothing 4 mm			
Speed regulation			adjustable exhaust valves			
Noise level	6) [dBA]		< 64			
Ambient: Temperature	[°C]		10–50			
Rel. humidity			< 95% (without condensation)			
Air purity			normal workshop atmosphere			
Guaranty period			2 years from the date of delivery			
Mounting position	2)		any			
Material			aluminum, steel			

- 1) Designation: KUS-piston diameter-stroke-shock absorber
- 2) For vertical applications, use compensating spring (see special accessories page 186: Installation kits for compensating spring)
- 3) See load calculations page 174
- 4) Scatter of the end positions for 100 successive strokes, conditions as for 6)
- 5) See assembly instructions page 176 and accessories page 302
- 6) Measured at 5 bar, maximum stroke horizontal, with $m = m_{h \max}$, throttled (approach end positions without impact)

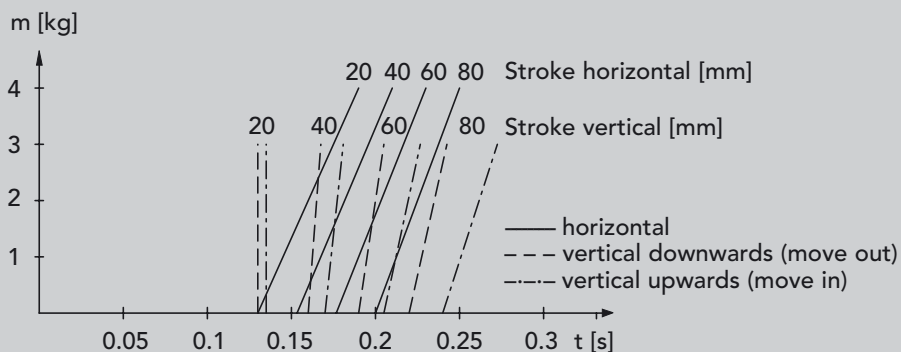
TRAVEL TIME DIAGRAM

$p = 5 \text{ bar}$

Vertical operation with compensating spring (with $m = 0 \text{ kg}$ untensioned, with $m = m_{v \max}$ fully tensioned)

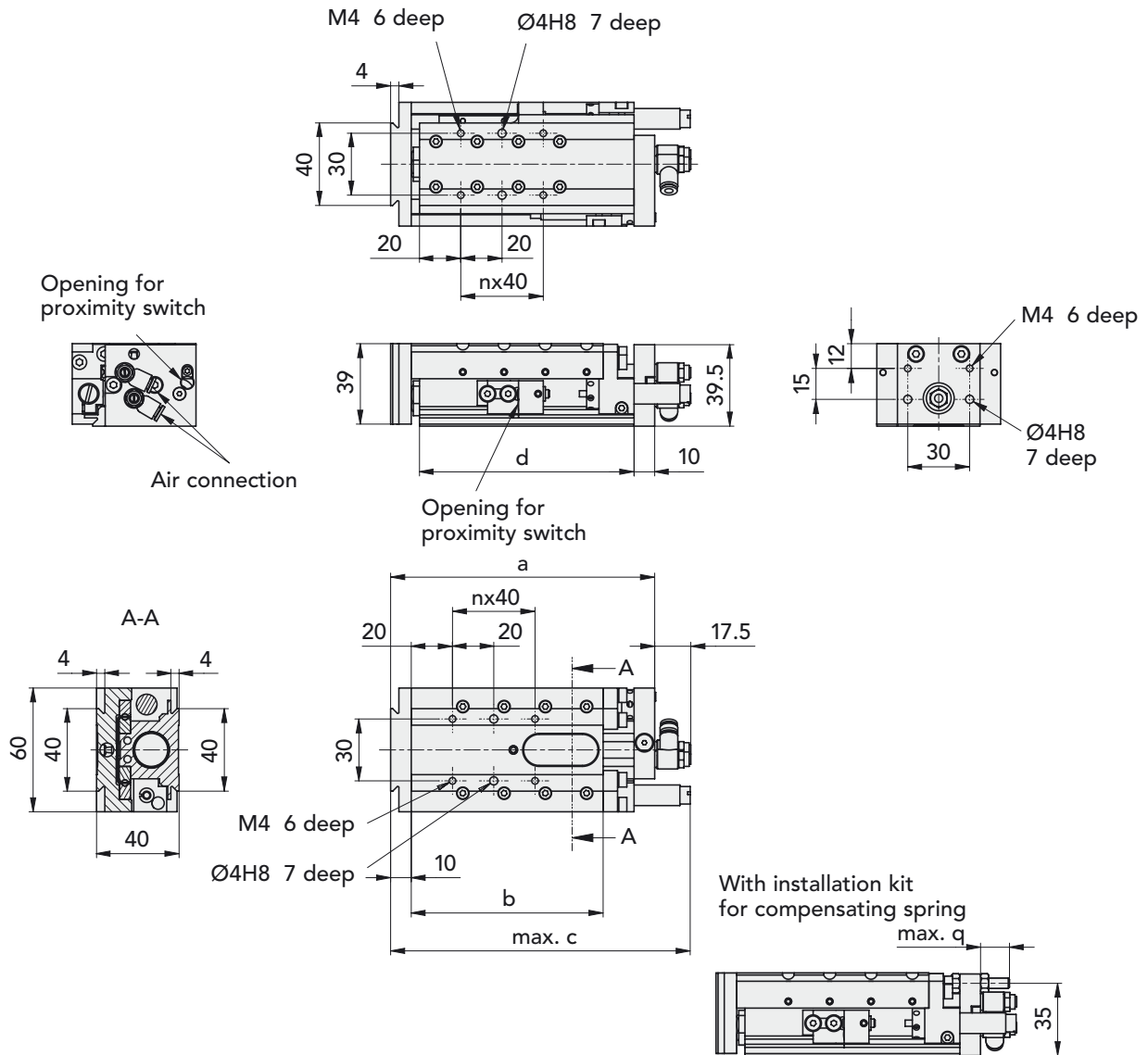

	a	b	c	d	n	q
KUS-16-20-SD	128	93	145.5	104	1	14
KUS-16-40-SD	154	119	171.5	130	2	24
KUS-16-60-SD	180	145	197.5	156	2	34
KUS-16-80-SD	206	171	223.5	182	2	44

Ref. No.
 KUS-16-20-SD
 KUS-16-40-SD
 KUS-16-60-SD
 KUS-16-80-SD

51540
51541
51542
51543

COMPACT UNIVERSAL SLIDES KUS-20-...-SD¹⁾

			KUS-20-40-SD	KUS-20-80-SD	KUS-20-120-SD	KUS-20-160-SD
Stroke (min./max.)	[mm]		10/40	10/80	40/120	80/160
Adjustment range for stops (per side)	[mm]		40	40	40	40
Piston diameter	[mm]		20	20	20	20
Piston-rod diameter	[mm]		8	8	8	8
perm. additional mass horiz.	$m_{h \max}$	[kg]	6	6	6	6
perm. additional mass vert.	$m_{v \max}$	2) [kg]	5	5	5	5
max. static moment	$M_{0x \max}$	3) [Nm]	22	27	32	37
max. static moment	$M_{0y \max}$	3) [Nm]	18	26	34	42
max. static moment	$M_{0z \max}$	3) [Nm]	18	26	34	42
max. static force (at 5 bar)	$F_{x \max}$	3) [N]	90	90	90	90
max. static force	$F_{y \max}$	3) [N]	180	210	240	270
max. static force	$F_{z \max}$	3) [N]	180	210	240	270
Weight	[kg]		1.3	1.6	1.9	2.2
Operating pressure	[bar]		3–6			
Operating medium			oiled or unoled air, filtered to 5 μm , dew point < 6°C			
End stop absorption			hydraulic shock-absorbers			
Repeatability	4) [mm]		< 0.01			
Check of end position	5)		inductive proximity switches			
Pneumatic connection			hose- \varnothing 6 mm			
Speed regulation			adjustable exhaust valves			
Noise level	6) [dBA]		< 64			
Ambient: Temperature	[°C]		10–50			
Rel. humidity			< 95% (without condensation)			
Air purity			normal workshop atmosphere			
Guaranty period			2 years from the date of delivery			
Mounting position	2)		any			
Material			aluminum, steel			

- 1) Designation: KUS-piston diameter-stroke-shock absorber
- 2) For vertical applications, use compensating spring (see special accessories page 186: Installation kits for compensating spring)
- 3) See load calculations page 174
- 4) Scatter of the end positions for 100 successive strokes, conditions as for 6)
- 5) See assembly instructions page 176 and accessories page 302
- 6) Measured at 5 bar, maximum stroke horizontal, with $m = m_{h \max}$, throttled (approach end positions without impact)

TRAVEL TIME DIAGRAM

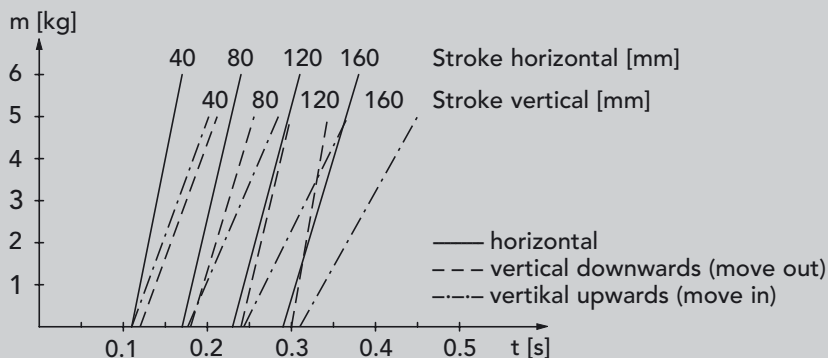

$p = 5 \text{ bar}$

Vertical operation with compensating spring (with $m = 0 \text{ kg}$ untensioned, with $m = m_{v \max}$ fully tensioned)

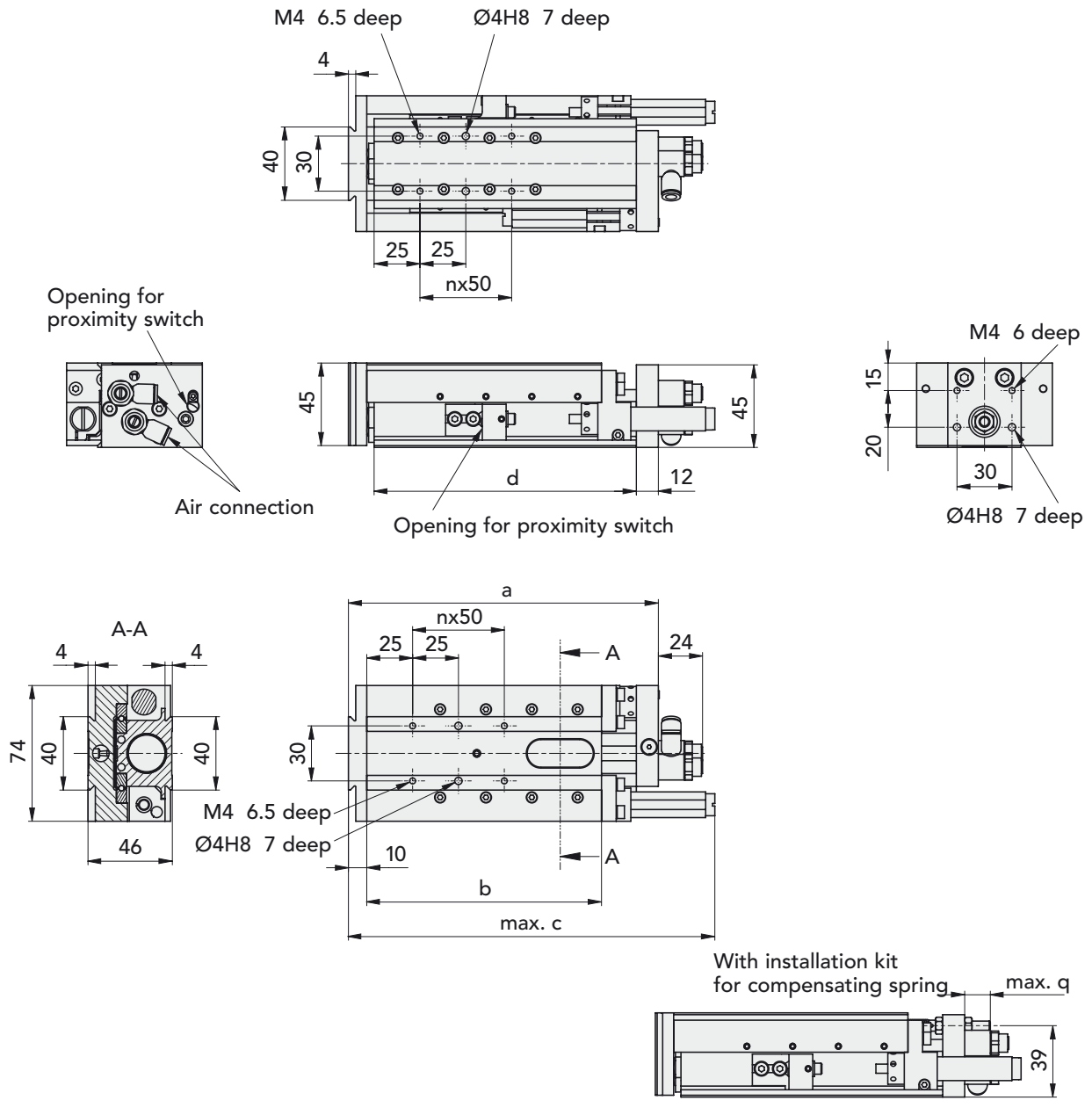

	a	b	c	d	n	q
KUS-20-40-SD	169	128	200	143	1	14
KUS-20-80-SD	221	180	252	195	2	24
KUS-20-120-SD	273	232	304	247	3	34
KUS-20-160-SD	325	284	356	299	3	44

Ref. No.

KUS-20-40-SD
 KUS-20-80-SD
 KUS-20-120-SD
 KUS-20-160-SD

51544
51545
51546
51547

COMPACT UNIVERSAL SLIDES KUS-25-...-SD¹⁾

			KUS-25-60-SD	KUS-25-120-SD	KUS-25-180-SD	KUS-25-240-SD
Stroke (min./max.)	[mm]		10/60	40/120	100/180	160/240
Adjustment range for stops (per side)	[mm]		40	40	40	40
Piston diameter	[mm]		25	25	25	25
Piston-rod diameter	[mm]		10	10	10	10
perm. additional mass horiz.	$m_{h \max}$	[kg]	10	10	10	10
perm. additional mass vert.	$m_{v \max}$	2) [kg]	8	8	8	8
max. static moment	$M_{0x \max}$	3) [Nm]	50	62	74	86
max. static moment	$M_{0y \max}$	3) [Nm]	44	66	88	110
max. static moment	$M_{0z \max}$	3) [Nm]	44	66	88	110
max. static force (at 5 bar)	$F_{x \max}$	3) [N]	150	150	150	150
max. static force	$F_{y \max}$	3) [N]	300	360	420	480
max. static force	$F_{z \max}$	3) [N]	300	360	420	480
Weight	[kg]		2.4	3.1	3.8	4.5
Operating pressure	[bar]		3–6			
Operating medium			oiled or unoled air, filtered to 5 μm , dew point < 6°C			
End stop absorption			hydraulic shock-absorbers			
Repeatability	4) [mm]		< 0.01			
Check of end position	5)		inductive proximity switches			
Pneumatic connection			hose- \varnothing 6 mm			
Speed regulation			adjustable exhaust valves			
Noise level	6) [dBA]		< 64			
Ambient: Temperature	[°C]		10–50			
Rel. humidity			< 95% (without condensation)			
Air purity			normal workshop atmosphere			
Guaranty period			2 years from the date of delivery			
Mounting position	2)		any			
Material			aluminum, steel			

- 1) Designation: KUS-piston diameter-stroke-shock absorber
- 2) For vertical applications, use compensating spring (see special accessories page 186: Installation kits for compensating spring)
- 3) See load calculations page 174
- 4) Scatter of the end positions for 100 successive strokes, conditions as for 6)
- 5) See assembly instructions page 176 and accessories page 302
- 6) Measured at 5 bar, maximum stroke horizontal, with $m = m_{h \max}$, throttled (approach end positions without impact)

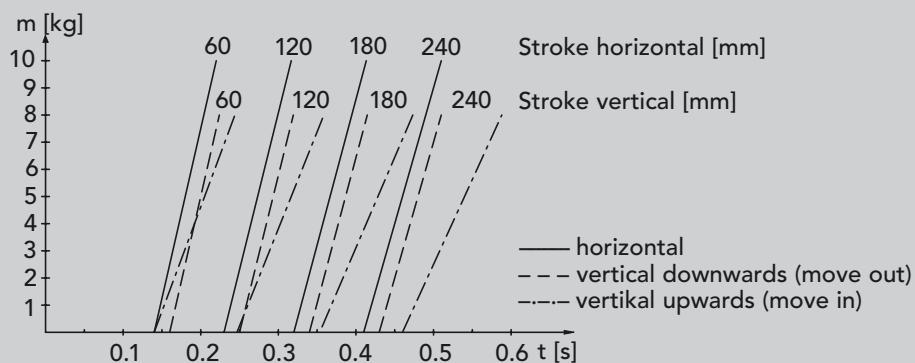
TRAVEL TIME DIAGRAM

$p = 5 \text{ bar}$

Vertical operation with compensating spring (with $m = 0 \text{ kg}$ untensioned, with $m = m_{v \max}$ fully tensioned)

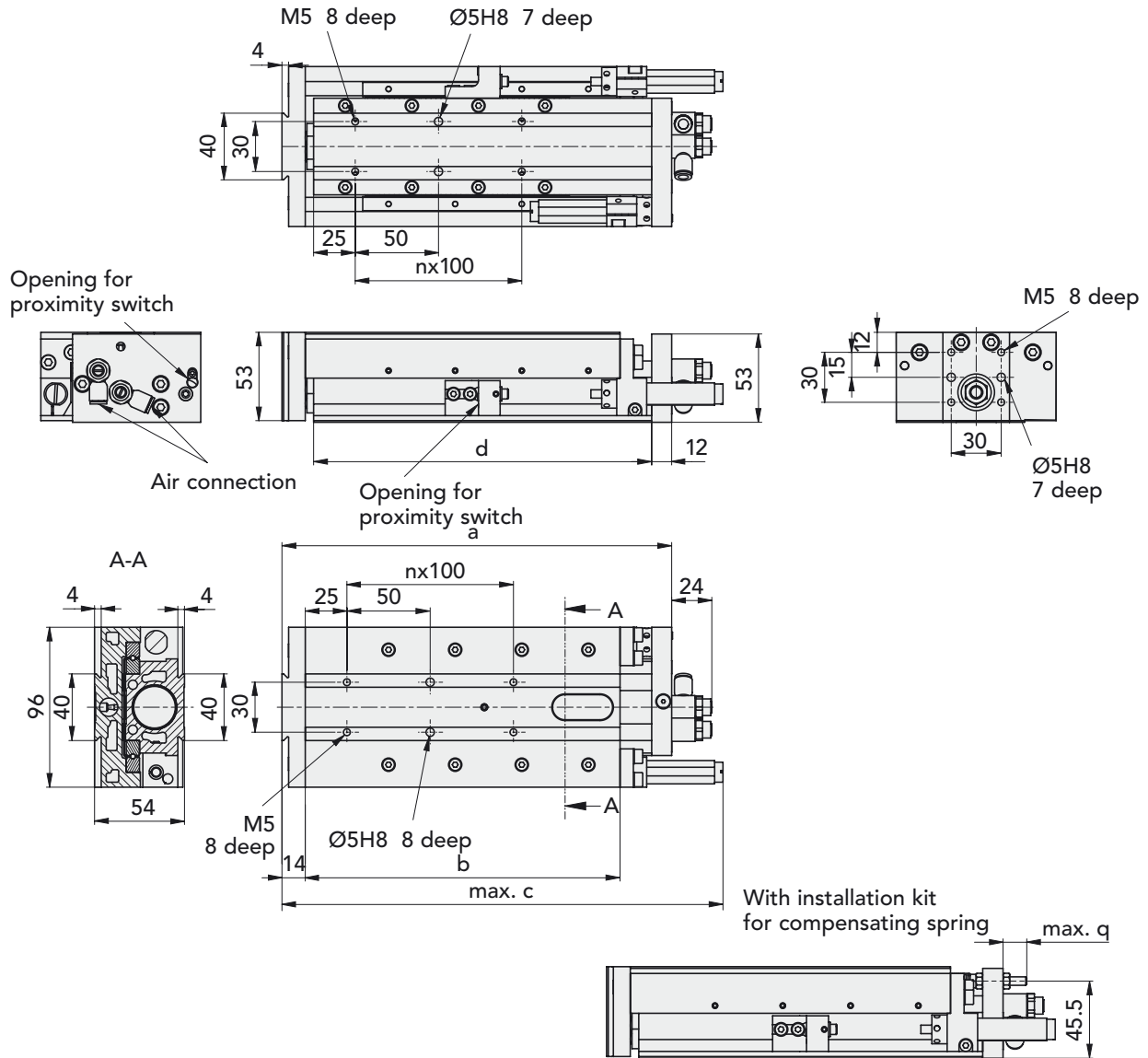

	a	b	c	d	n	q
KUS-25-60-SD	234	189	265	203	1	14
KUS-25-120-SD	318	273	349	287	2	24
KUS-25-180-SD	402	357	433	371	2	34
KUS-25-240-SD	484	439	515	453	3	44

Ref. No.

KUS-25-60-SD
 KUS-25-120-SD
 KUS-25-180-SD
 KUS-25-240-SD

51548
51549
51550
51551

SPECIAL ACCESSORIES KUS



INSTALLATION KITS FOR COMPENSATING SPRING

Tension spring with clamping bolt and two hexagon nuts for installation for vertical application:

	Ref. No.
Installation kit for compensating spring to KUS-16-20-SD	51631
Installation kit for compensating spring to KUS-16-40-SD	51632
Installation kit for compensating spring to KUS-16-60-SD	51633
Installation kit for compensating spring to KUS-16-80-SD	51634
Installation kit for compensating spring to KUS-20-40-SD	51635
Installation kit for compensating spring to KUS-20-80-SD	51636
Installation kit for compensating spring to KUS-20-120-SD	51637
Installation kit for compensating spring to KUS-20-160-SD	51638
Installation kit for compensating spring to KUS-25-60-SD	51639
Installation kit for compensating spring to KUS-25-120-SD	51640
Installation kit for compensating spring to KUS-25-180-SD	51641
Installation kit for compensating spring to KUS-25-240-SD	51642

ESCAPEMENT VS

		VS-30	VS-60
Stroke (min./max.)	[mm]	0/30	25/60
Piston diameter	[mm]	16	16
Piston-rod diameter	[mm]	6	6
Force to move in/out at 5 bar	[N]	60	60
Weight	[kg]	0.840	1.140
Operating pressure	[bar]	4–8	
Operating medium		air, oiled or unoled, filtered to 5 µm, dew point < 6°C	
Reproducibility	1) [mm]	0.02	
Check of end positions	2)	hydraulic shock-absorbers	
Pneumatic connections		hose-Ø 4 mm	
Speed regulation		adjustable exhaust valves M5	
Ambient: Temperature	[°C]	10–50	
Rel. humidity		< 95% (without condensation)	
Air purity		normal workshop atmosphere	
Guaranty period		2 years from the date of delivery	
Maintenance		When permanently loaded in the y direction, we recommend oiling the surface of the guide every 2 months	
Material		steel, cast iron, bronze	

1) Difference in end positions during 100 successive strokes

2) See accessoris page 302



VS, two sizes

SCOPE OF DELIVERY

The isolating devices are delivered with two exhaust valves and two plastic sleeves for proximity switches.

SUITABLE ACCESSORIES

Accessories
Quick-Set®

from page 302
from page 338

VS

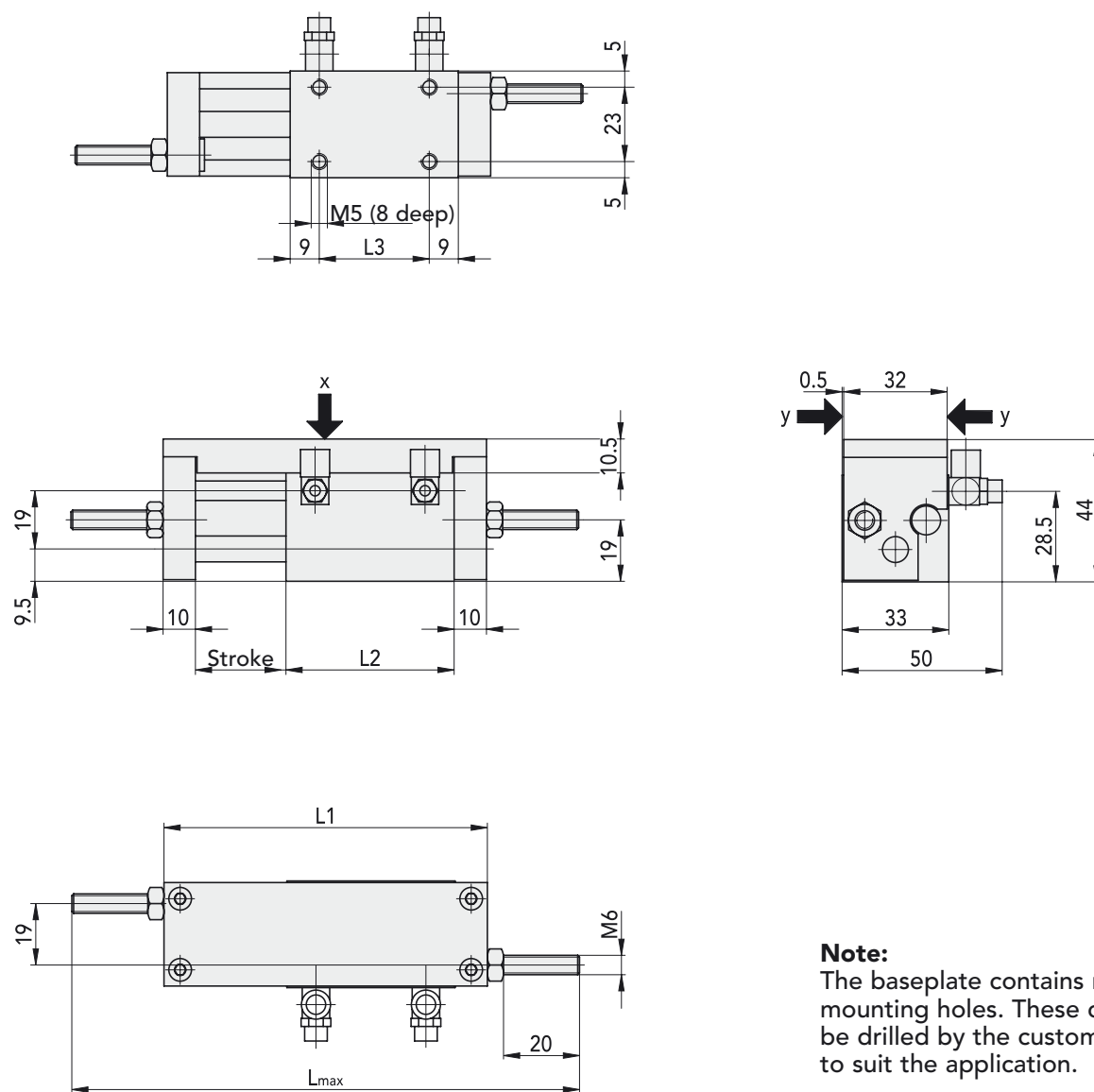
**Note:**

The baseplate contains no mounting holes. These can be drilled by the customer to suit the application.

European projection

	L1	L2	L _{max}	L3	X _{adm}	Y _{adm}
VS-30	108	57	158	39	30 N	50 N
VS-60	168	87	218	69	25 N	50 N

Ref. No.
VS-30
VS-60

45194
45209